

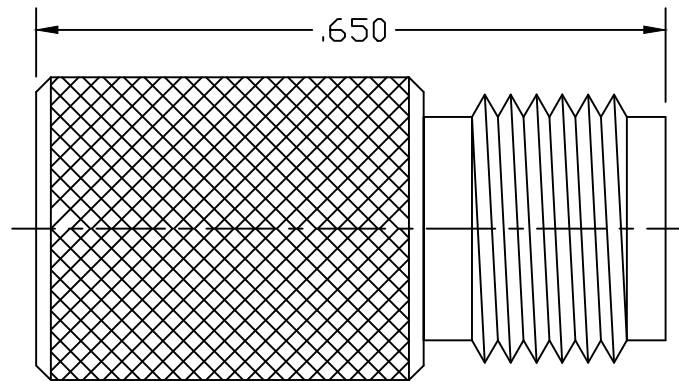

NOTES:

010-99-043



| | | | | | | | | | | |
|-----|-------------|-------|-------|--|----------------------|------------------------------------|--|------------------------------------|-------------------|------------|
| LTR | DESCRIPTION | DATE | APPR. | DRAWN <i>LMW</i> | CHECKED | USED ON |  SRI CONNECTOR GAGE CO. 751 NORTH DRIVE MELBOURNE FL. 32934 | | | |
| - | REL | 09/03 | | APPR. | SCALE | 2.9mm TO .085 S/R | | | | |
| | | | | UNLESS OTHERWISE SPECIFIED: 1. REMOVE ALL BURRS 2. BREAK ALL CORNERS & EDGES .005 R. MAX 3. CHAMFER 1st & LAST THREADS 45° 4. SURFACE FINISHED 32/ UNLESS OTHERWISE SPECIFIED. 5. DIAMETERS ON COMMON CENTERS TO BE CONCENTRIC WITHIN .002 T.I.R. 6. ALL DIMENSIONS ARE AFTER PLATING. | | | MATERIAL | TITLE | | |
| | | | | DIMENSIONS ARE IN INCHES TOLERANCES | | | FINISH | ASSEMBLY TOOL 2.9mm TO .085 S/R | | |
| | | | | DECIMALS .X ±.030 .XX ±.010 .XXX +.005 | FRACTIONAL ± 1/64 | ANGULAR .X° ±1°0' .X°X' ±15' | SIZE A | | FSCM NO. OHMO1 | SHEET 1 |